



DE-LUXE SCALE SERIES D.H. CHIPMUNK

21" SPAN
RUBBER MODEL
CAT No 733FK

DESIGNED
&
DRAWN BY

0 50 100 150 mm

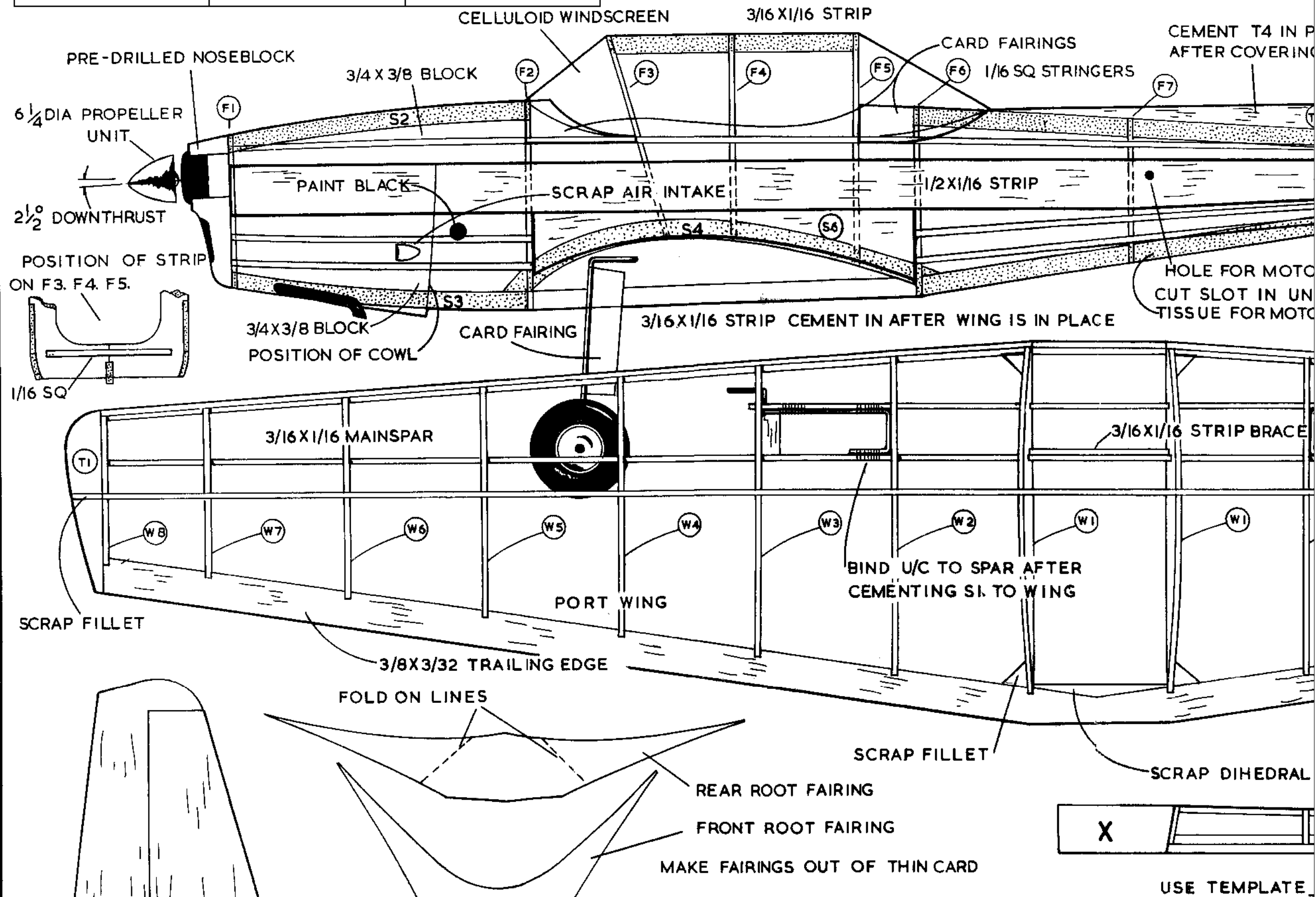

USE TEMPLATE

K 21" SPAN
RUBBER MODEL
CAT No 733FK

DESIGNED
&
DRAWN BY

Bill Knox

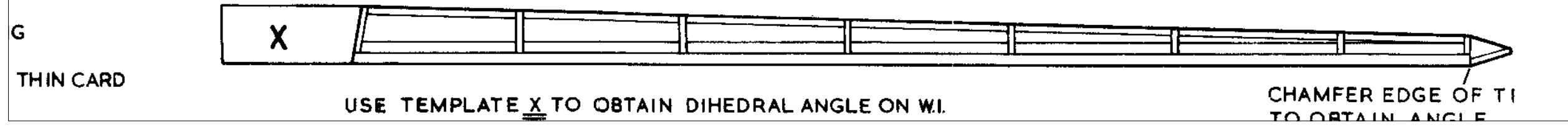
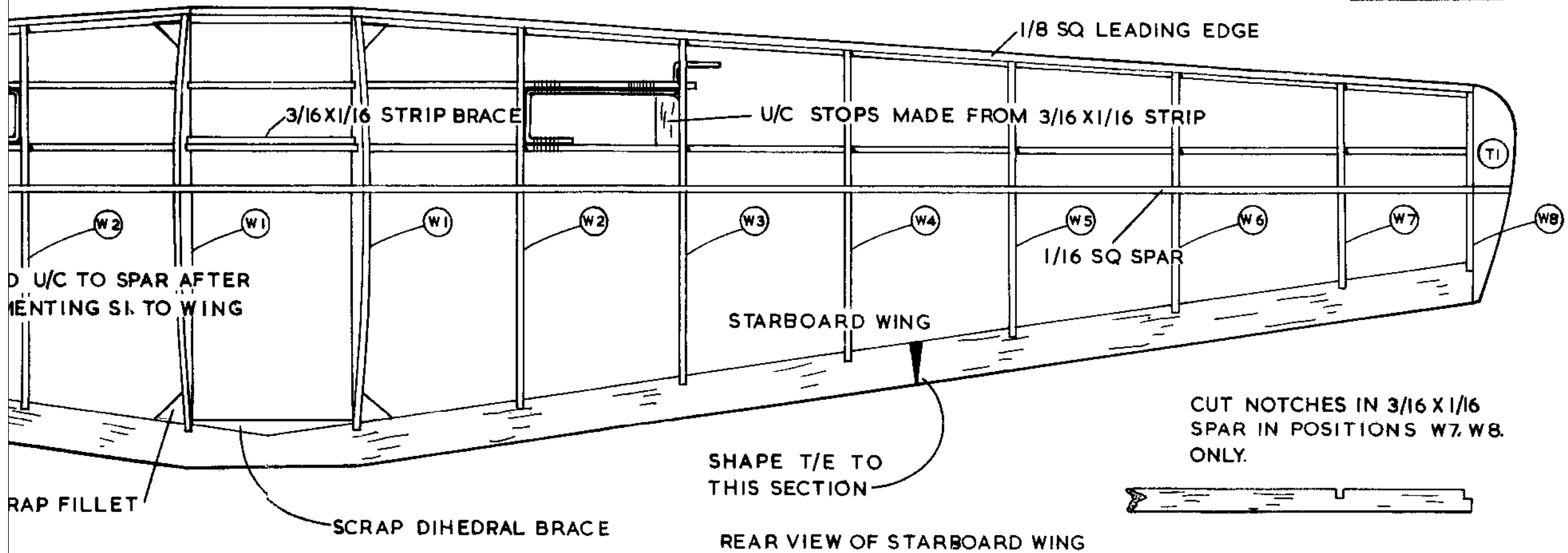
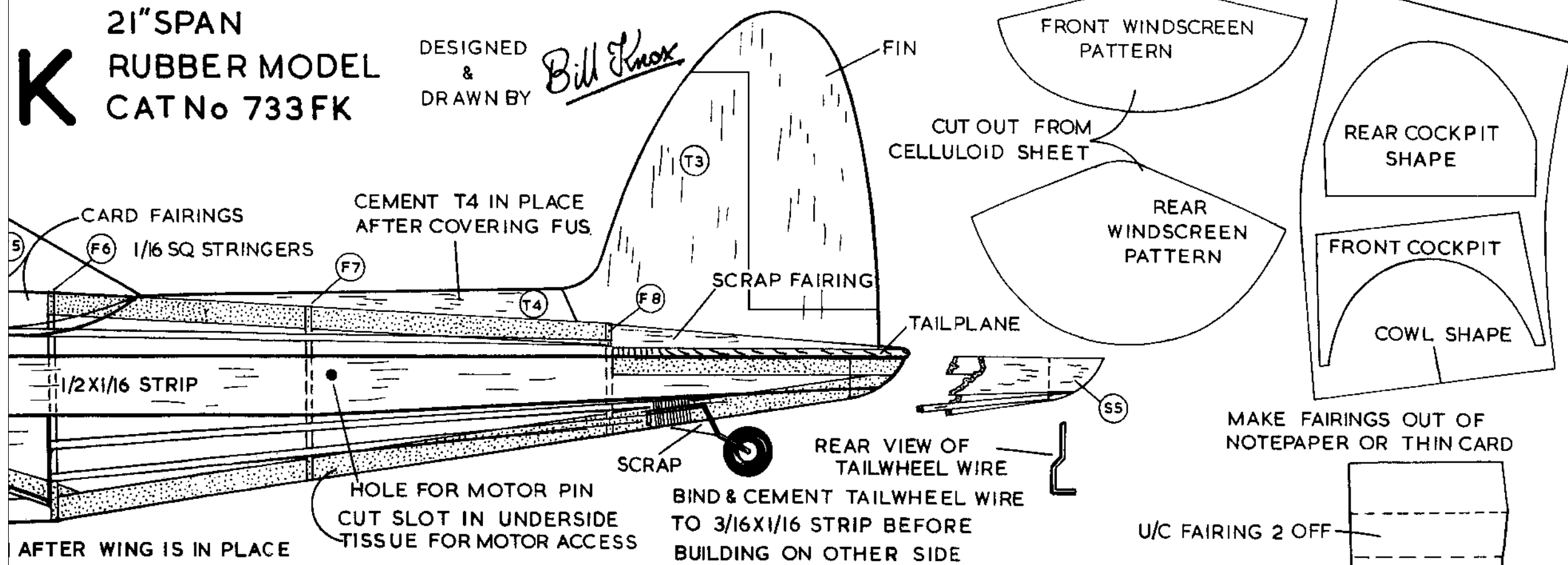

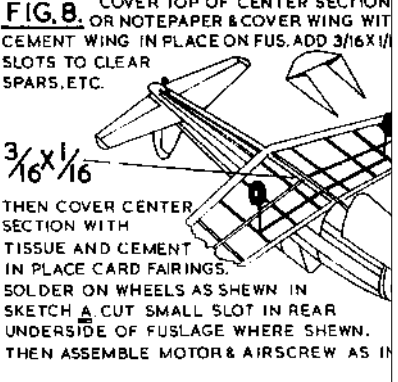
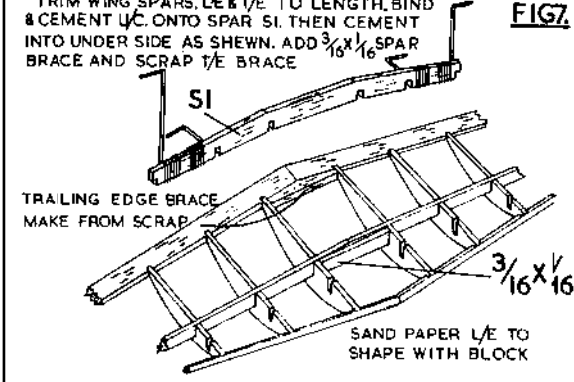
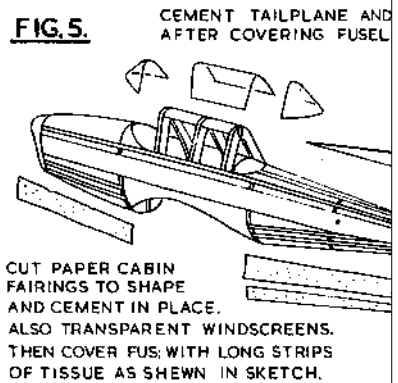
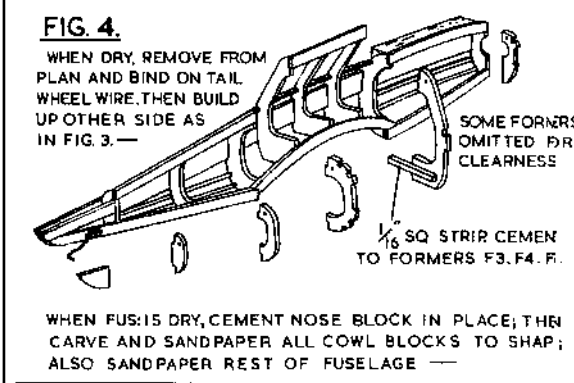
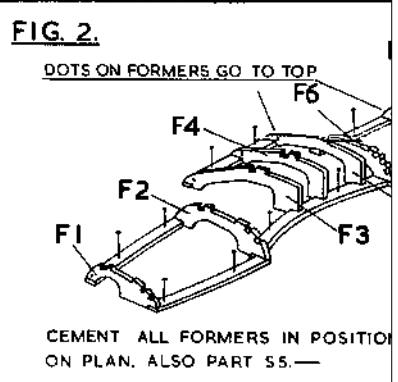
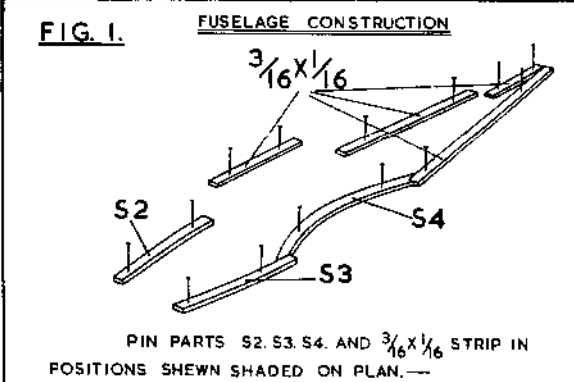
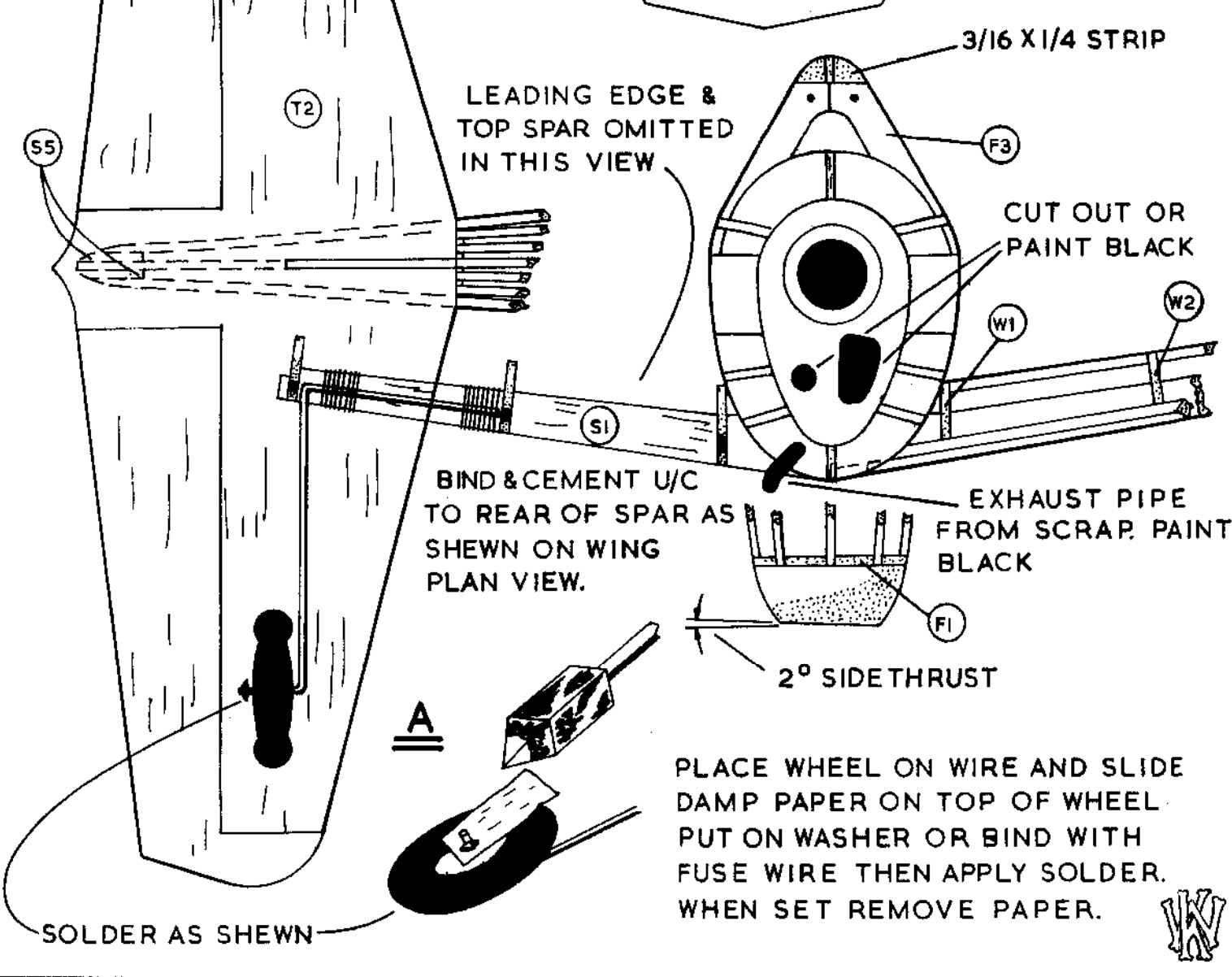
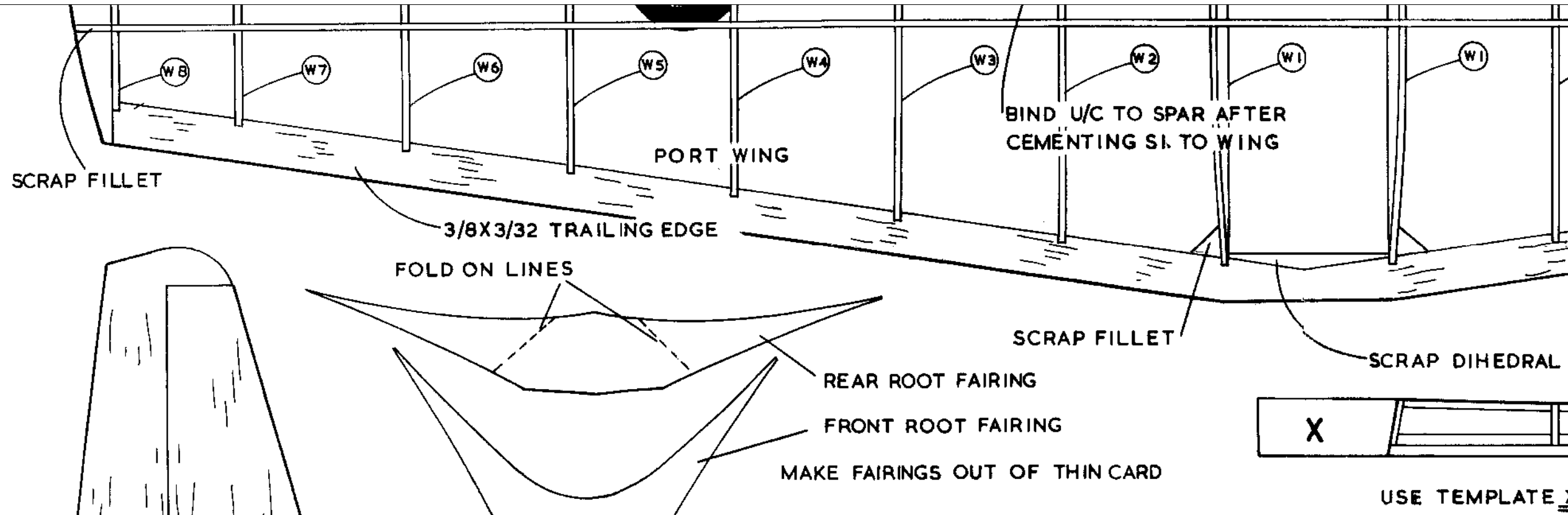

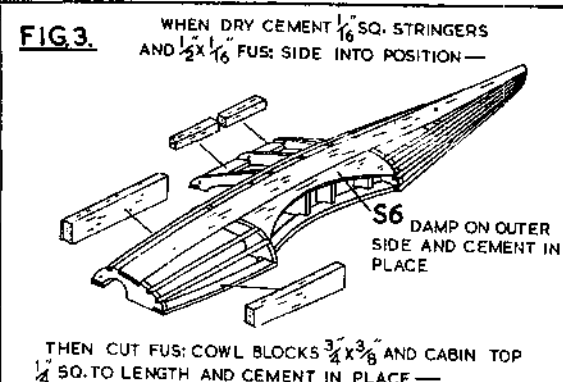
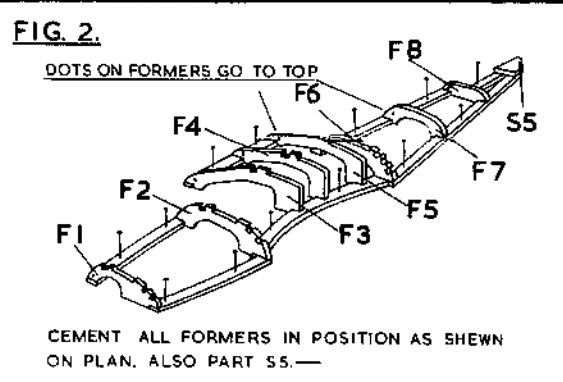
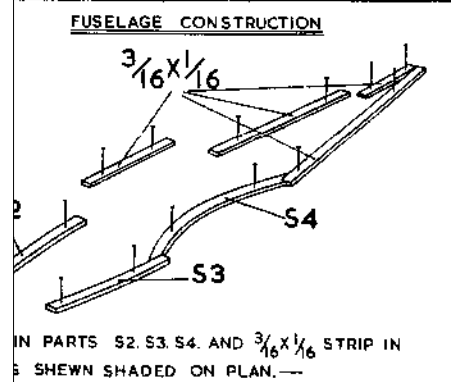
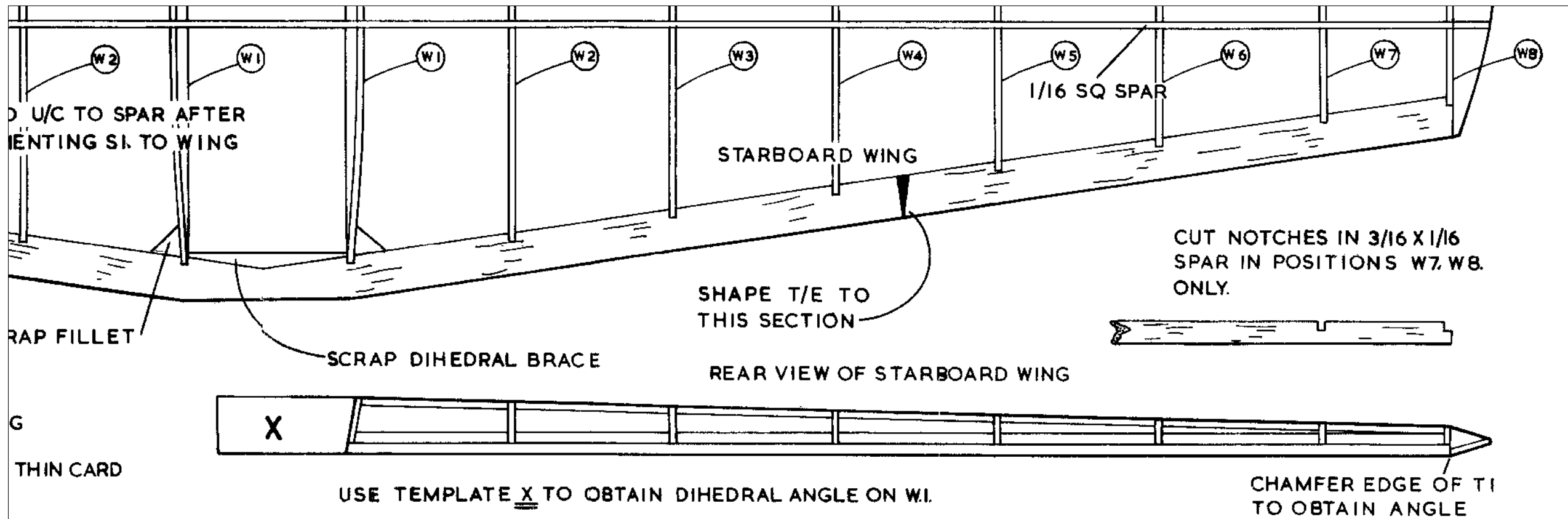

INTRODUCTION

This Model is one of the FROG DE-LUXE SCALE SERIES which consists of a range of Models representing popular full-size aircraft. To ensure a satisfactory job carefully study the plan and check the parts with it before cementing them together. As with other Frog Models most of the parts are supplied ready cut to shape for easy assembly. Cement and dope are not included in this Kit but they can be bought at any Model Shop. Use quick-drying balsa cement such as FROG UNIVERSAL, you will also need a sharp balsa knife or single edge razor blade and a few pins.

BUILDING

Lay a sheet of grease-proof paper over plan and bend all wire parts to shape before commencing construction. IT IS MOST IMPORTANT THAT ALL FORMERS IN THE FUSELAGE ARE CEMENTED IN AN UPRIGHT POSITION AS SHOWN ON FUSELAGE SIDE VIEW. Before building the fuselage cut to shape the two 1/2 x 1/16 strips as shown in heavy outline on plan, then build up fuselage as in Figs. 1 to 5. Build wings as in Figs. 6 to 8 and cover with tissue before cementing in place to fuselage.

Covering

Cover the Model with the tissue supplied using office paste or clear dope as an adhesive.

Wings Cut the tissue to approximate shape leaving a 1/8" margin all round. Apply adhesive to underside edges of wing then lay the tissue over it and pull gently all round. Do not attempt to get it drumtight, but aim at getting an even surface, with no deep wrinkles. When dry trim off excess and cover the top side.

Cover this fuselage with long strips as shown in Fig. 5, covering one bay at a time and gradually working round until complete. Then cover fin and tailplane and part T.4 applying adhesive to edges and pulling tissue over and trimming off excess.

Before applying clear dope lightly spray or brush each item with water pinning wing and tailplane down on a flat board to prevent warping. When thoroughly dry apply a thin coat of clear shrinking dope to each part, pinning wing, tailplane and fin down onto a flat board covered with grease-proof paper to prevent sticking. When dry give fuselage two more thin coats of dope and the wing one. (If Model is to be used for flying do not use colour dope unless sprayed on thinly.) Many different colour schemes can be used as this Aircraft is in service with many Air Forces, and also in civil use.

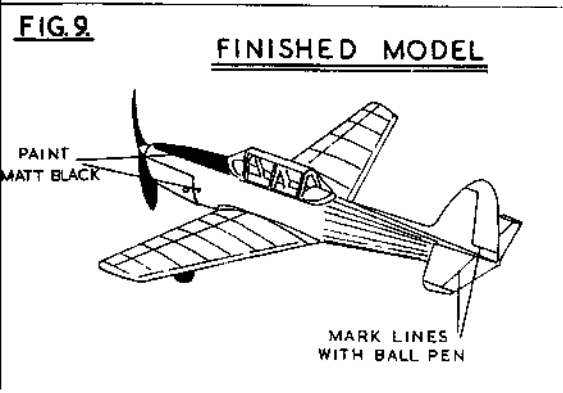
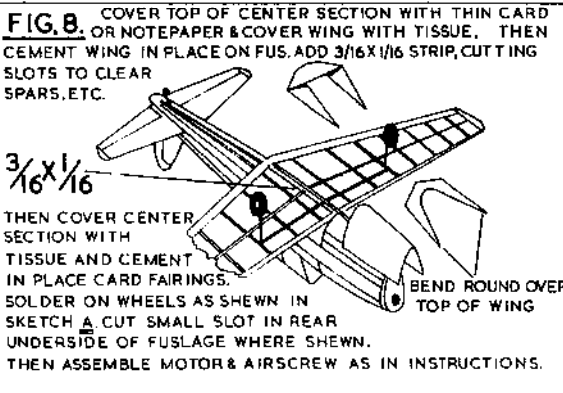
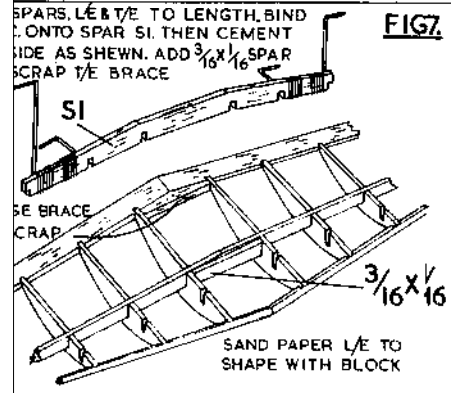
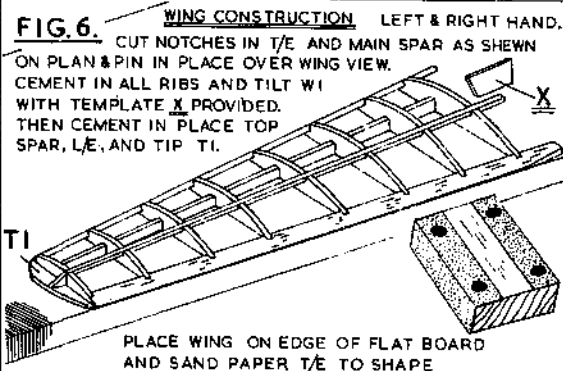
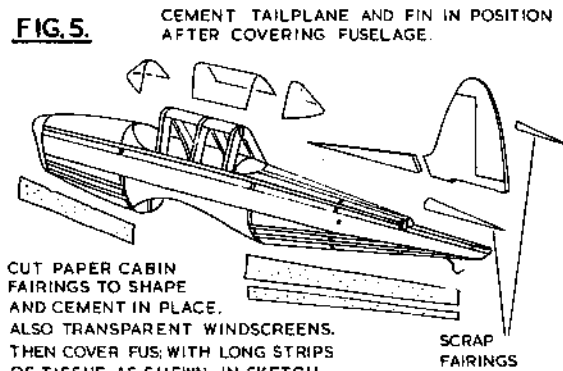
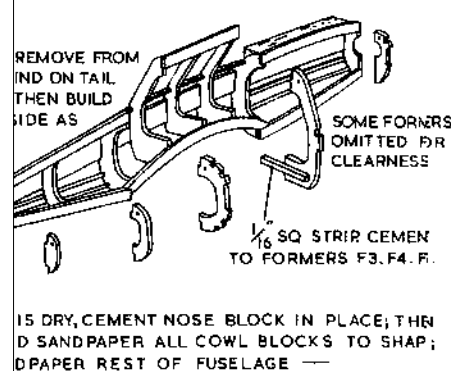

Soldering

Clean parts to be soldered with glasspaper, then apply flux to parts to be joined. Heat up soldering iron and clean tip with file, dip in small container of flux and apply solder on to end of iron, then apply iron to joint until solder flows round it. When set wipe off excess flux to prevent rusting.

Motor

This is composed of two 9" elastic bands which are supplied. Lubricate them with Frog Rubber Lubricant or Castor Oil, and insert them into the fuselage with the help of a length of wire or thread. Bend a hook at one end of the wire and insert it into the front end of the fuselage. (If a thread is being used, tie a weight to one end and drop it through.) Hook the bands on to it through the opening at the rear and insert the rear motor pin (cane) through the holes in the fuselage and through the loops of elastic. Pull the bands out through the front, and hook them on to the airscrew shaft (complete with Airscrew). The model is now complete and ready for flying. A drop of thin oil on the airscrew shaft will improve the running.

Flying

This model is intended to be flown out of doors, but choose a very calm day for your first test. The model should balance level when held on the fingertips at front spar position on wing. Small pieces of plasticine should be added to nose or tail until balance is correct. Test glide the model to check the balance. Hand launch it in a slight downward direction. If it dives add weight to the rear of fuselage, if it climbs sharply and drops back on tail (this is called stalling) add weight to the nose. When the glide seems satisfactory put a few turns on the motor and launch the model into wind (if any). The turn can be adjusted by bending the fin. Increase the turns on the motor gradually, up to a maximum of approximately 300; if the motor is not lubricated, the turns must be limited to 150. An unlubricated motor will wear and break very quickly. Stretching the elastic while winding will enable more turns to be obtained. If model stalls under power, cement a thin strip of balsa between top of nose plug and nose block.

Produced in England by INTERNATIONAL MODEL AIRCRAFT LTD.
Morden Road, Merton, London, S.W.19