

FROG

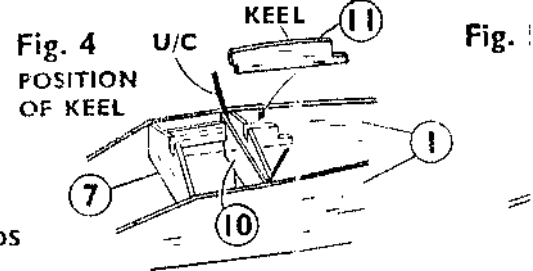

"CESSN

SIDE VIEW

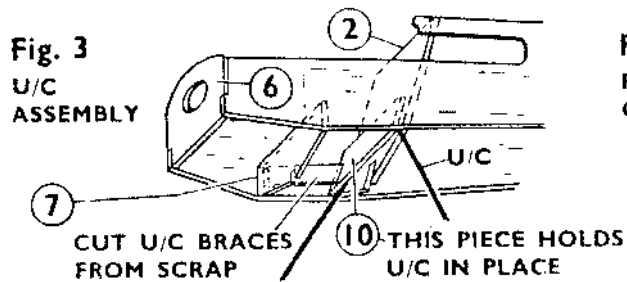
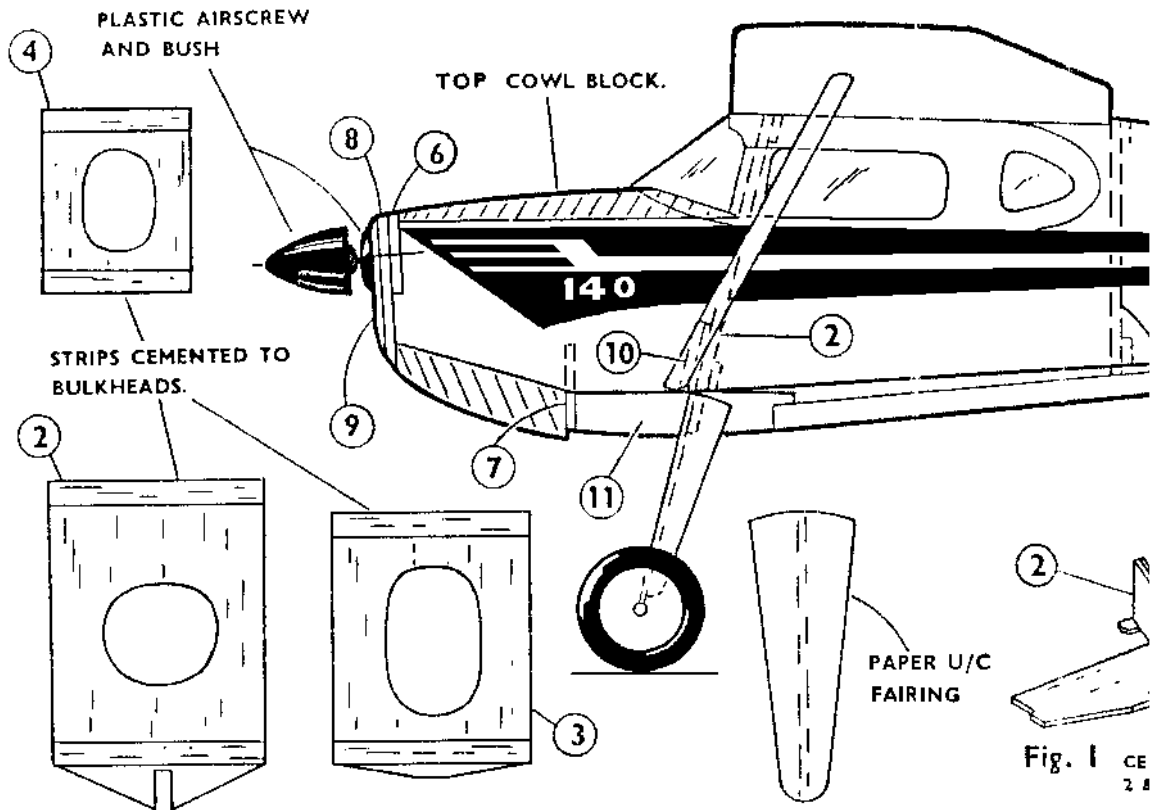

INTRODUCTION.

The Frog Junior Scale Series covers a range of models which are based on the designs of various service and light aircraft. In common with other Frog models, they embody very simple construction methods having all the parts cut to shape, which only require cementing together.

To ensure a satisfactory job, study the plan and check the parts with it before commencing. Assemble the model step by step as shown.

Cement and "dope" are not included in this kit, but they can be bought at any model shop. Use quick-drying balsacement (glue) such as Frog Universal. You will also need a balsa knife or razor blade and a few pins.

If you enjoy building this model, remember there are many others in this series equally attractive.

BUILDING INSTR

FUSELAGE ASSEMBLY.

Carefully remove all the parts from balsa knife or a piece of razor-blade to clean edge. Start by marking the bulkhead pieces 1 from the side-view drawing. Cut a balsa strip cut from scrap, to bulkheads 2 and 3 to one of the side panels, as shown they are upright, and allow to dry. Then place with bulkheads 4, 5 and 6, as in fig. 1.

UNDERCARRIAGE.

Cement the shaped wire piece into head 2.

This is held in place by piece 10, a wire, see fig. 3. Two pieces of scrap balsa 7 and 10, add to the strength of the undercarriage.

CESSNA

JUNIOR SCALE SERIES

SIDE VIEW (Full size)

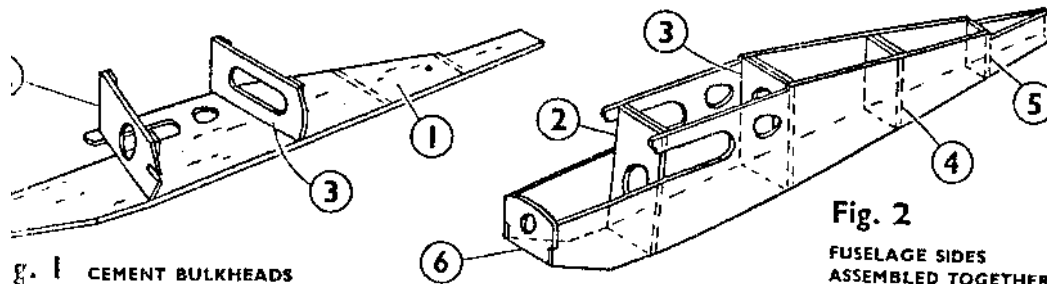
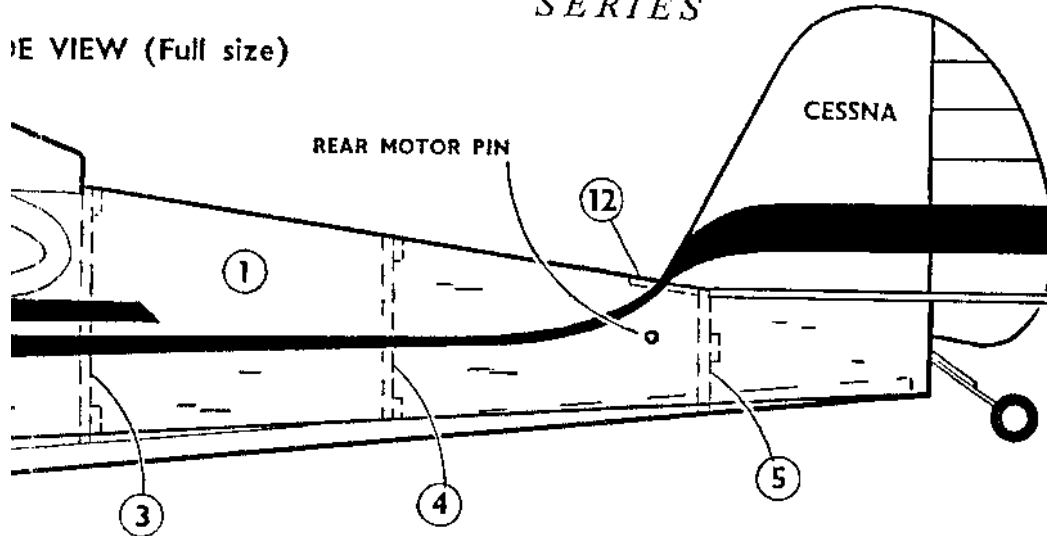

Fig. 1 CEMENT BULKHEADS 2 & 3 IN PLACE FIRST.

Fig. 2 FUSELAGE SIDES ASSEMBLED TOGETHER.

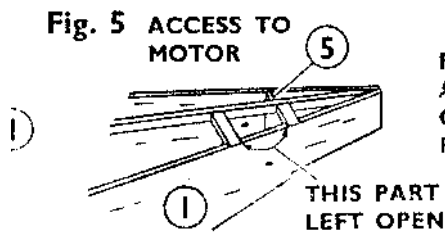
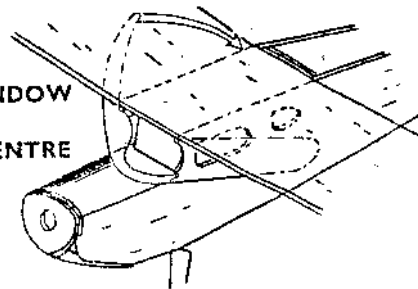

Fig. 5 ACCESS TO MOTOR

Fig. 6 FIT CABIN WINDOW AFTER WING. CEMENT AT CENTRE FIRST



INSTRUCTIONS

Cut parts from the balsa sheet using a sharp knife. Then cement pieces of bulkheads 2, 3 and 4, and cement sides, as shown in fig. 1. Make sure they are square. Then cement the other side in place, as in fig. 2. Next cement part 7

piece into place in front of bulk-

head. Cement piece 10, well cemented over the scrap balsa glued between parts 8 and 9, and fit the top cowl-

ing. Fit the wheels in place and bend the ends of the wire over, and glue small paper washers to the axles to hold them on. Cut the two fairings from paper to the shape given, and glue them to the wire legs.

KEEL.

Cement the keel, part 11, into the slots in bulkheads 2 and 7, fig. 4. Cut bottom stringer from spare balsa sheet, and glue it into place from keel to end of fuselage.

ACCESS TO MOTOR

Cut two small pieces of scrap balsa and cement them to the underside of fuselage on one side; fig. 5.

COWLING.

Sandpaper the ends of the lower block to the angle shown in Side View, and cement it into place. Then cement parts 8 and 9, and fit the top cowl-

ing piece in place. Shape the blocks with a sharp knife or razor blade and sandpaper them smooth.

FROG
FLYING MODELS



“CESSN

INSTRUCTIONS (contd.).

WING.

Remove the cut-out wing from the panel, and sandpaper the edges before fixing. Place it on a flat board or table, hold down the centre part with weights or pins, and raise the tips approx. $\frac{1}{2}$ in., see fig. 7. Apply cement along crease lines and allow to dry.

When this has set, cement the wing in place in front of bulkhead 3 and on top of bulkhead 2.

The struts are made from spare balsa sheet. Cut two pieces $3\frac{1}{2}$ in. long, sandpaper them, and bevel the ends to fit. Cement them in place as shown on side view drawing.

TAIL ASSEMBLY.

Remove the Tailplane and Fin from the balsa sheet, and lightly sandpaper the edges. Cement them into place on the fuselage, and make sure they are quite “square” with it and the wing when viewed end on.

CABIN.

Cement the cabin window in place next, starting at the centre, see fig. 6, and allow this to set. Then bend the sides round and cement them into place.

TAILWHEEL.

This is made up of a round piece of balsa pressed out of one of the nose bulkheads, and a pin. Cut the head off the pin and push it into the rear of the fuselage and push the piece of balsa on to the end of the pin, glue as you assemble, see side view drawing.

COVERING.

Only the fuselage top and bottom need covering. It is suggested that the fuselage underside between bulkheads 2 and 7 be covered with thin note paper. Cut two strips of tissue about 7 in. long by 1 in. wide for the underside, and a piece $3\frac{1}{2}$ in. by $1\frac{1}{2}$ in. for the top side. Use paste or clear dope for sticking these to the fuselage. Trim off excess tissue afterwards with a razor blade. Carefully damp these surfaces, and when dry apply a coat of clear dope with a soft brush.

DECORATING.

The balsa wood parts being ready-printed, very little, if any, painting is necessary, and should be restricted to the top part of the fuselage. Use Cellulose Lacquer, and apply it quickly and evenly with a soft brush. Do not put it on heavily, or the model will not fly well.

MOTOR.

This is an elastic band 6 in. long. Lubricate it with Frog Rubber Lubricant, or Castor Oil, and insert it with the help of a length of wire or thread. Bend a hook at one end of the wire and insert it into the front end of the fuselage. Hook the band on to it through the opening at the rear, and insert the rear motor pin (cane) through the holes in the fuselage and through the loop of elastic. Pull the band out through the front and hook it on to the Airscrew shaft (complete with airscrew). The model is now complete and ready for flying. A drop of thin oil on the airscrew shaft will improve the running.

FLYING.

This model can be flown indoors or out, but it should only be used out-doors on a calm day, owing to its size.

A slight difference in balance may be shown with each individual model, owing to the varied density and weight of balsa wood.

⊥ ⊥ ⊥ ⊥
NA''

CAT. No. 580FK.

**Fig. 7 RAISE WING TIPS
AND CEMENT ALONG
CREASE LINES**

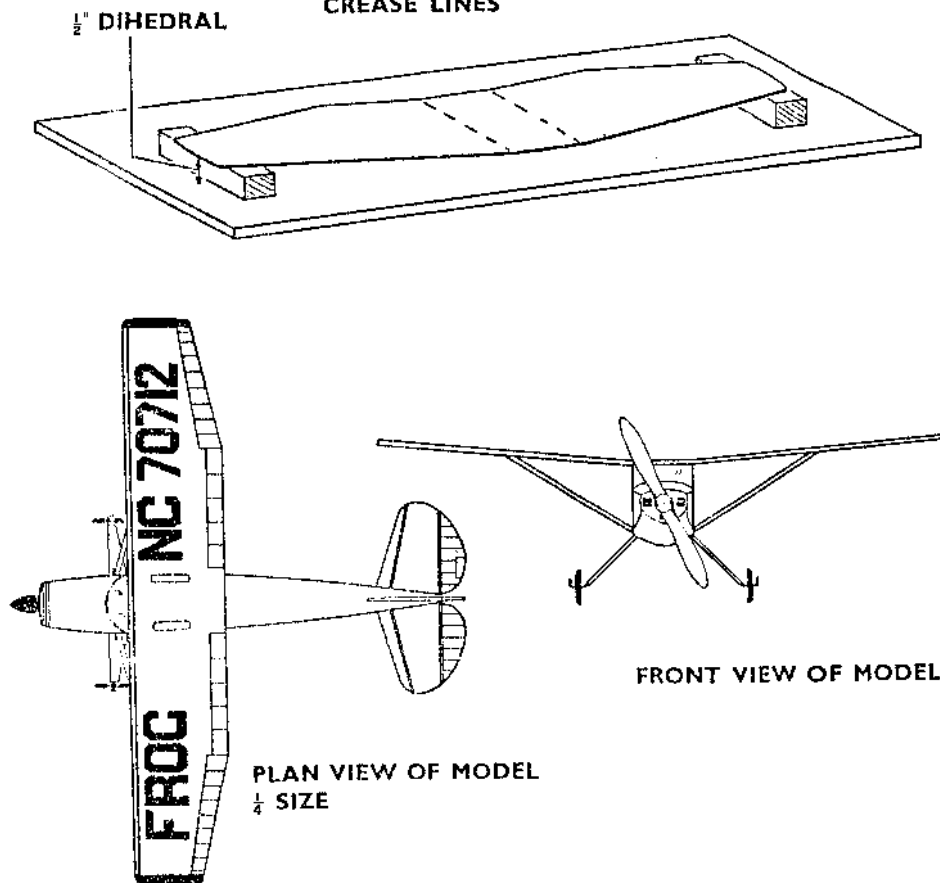

Test-glide the model first to check the balance. Hand-launch it in a slight downward direction. If it dives to the ground, add a small weight such as a small nail or pin to the rear end of the fuselage. If the model climbs steeply and stalls, add a small weight to the nose of the fuselage. A small nail or drawing pin can be pushed into the cowl block for this.

When the glide seems satisfactory, put a few turns on the motor and launch the model into wind (if any). The turn can be adjusted by bending the fin, or by twisting the wing slightly.

Increase the turns on the motor gradually, up to a maximum of approximately 300; if the motor is not lubricated, the turns must be limited to approximately 150.

Designed and Made in England by
INTERNATIONAL MODEL AIRCRAFT LTD.

MORDEN ROAD, MERTON, LONDON, S.W.19.

Printed in England.